

ISSUE	AMENDMENT
CLIENT	STD PRODUCT

DIMENSIONS IN mm UNLESS OTHERWISE STATED © ALTRON COMMUNICATIONS EQUIPMENT LTD. ALL RIGHTS RESERVED DO NOT SCALE			
TITLE AW1859 TILT DOWN POLE ASSEMBLY DIAGRAMS FOR – PT No'S AW1859/9 AW1859/10 & AW1859/12			
DRAWN GIJ	CAD RELEASE-1	MATERIAL EN10219	FINISH GALVANIZE TO ISO 1461

ALTRON COMMUNICATIONS EQUIPMENT LTD
TOWER HOUSE
PARC HENDRE
AMMANFORD SA18 3SJ
TEL: (01269) 831431
FAX: (01269) 845348
e-mail: comms@altron.co.uk ALTRON

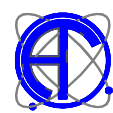

PRODUCT	DATE
AW1859/9-12	MAY 14
ASSEMBLY	
DWG. No.	-



Altron Communications Equipment LTD

Issue date November 2012

Tubular Tilt-Down Poles with double luffing – Operating Instructions

For part numbers AW4460/7, AW4460/8 – AW1859/7, AW1859/8,
AW1859/9, AW1859/10 & AW1859/12

ALTRON Poles are manufactured to a high standard and designed to be as simple and as safe as possible to operate. However, as with all mechanical equipment they require correct operation to ensure safety and performance.

Safety Precautions – Read These Before Operation

1. OBSERVE THE STATED LOADING VALUES, DO NOT OVERLOAD THE POLE.
2. Ensure the area in line with the fall of the pole is kept clear of all personnel when raising and lowering. Do not stand behind or below pole when operating; stand to the side. If in a public access area, make the area safe by means of a barrier.
3. Maintain winch and winch cable in good condition. Consult winch operating & maintenance notes below.
4. Before each tilting operation check that the cables are correctly seated in their pulleys. Check for signs of fraying or wear on the cable and that the splicings are secure. Check that cable is wound tightly onto the winch drum and no trapped loops exist. If unsure, wind cable off of the drum and re-wind on to ensure it is evenly layered
5. Before operating the pole, ensure that the area around the base of the pole is clear and that there are no trip hazards.
6. To ensure safe operation, concentrate on all aspects of the operating procedure at all times and be aware of the safety of those around you.

To Operate – (read in conjunction with assembly diagram)

1. Slot winch unit onto post.
2. Push eye end of cable under the pulley inside the bottom of the door frame (through 'T' slot on 9, 10 & 12m models), underneath and behind the pulley in the rear of the compartment and anchor between lugs, in the front of the compartment above the front pulley.
3. Before tilting the pole ensure the cable is wound tightly on to the winch drum, layered evenly and the cable eye end is securely anchored. Ensure slack is taken up so that the winch cable is pulling the pole onto the post.
4. Remove the 2no retaining nuts from the retaining bolts, located in the rear of the compartment behind the access door and then remove the 2no retaining bolts. The pole is now held entirely on the winch. **Do not remove the retaining nuts and bolts unless the winch and cable are correctly fitted to the pole.**

5. Wind the winch handle 'out' (winding handle anti-clockwise) half a turn (180 degrees) to allow enough slack for the pole to start lowering. It will be necessary to push the pole away from the post and continue this operation until the pole section has tilted far enough to carry on unaided.

Continue to wind winch handle 'out' to lower pole. Use a steady even action on the winch handle so that the pole does not bounce. A jerky operation of the winch handle will cause the pole to bounce which is not desirable.

6. Ensure the winch cable has tension on it, as a result of the pole weight, at all times during the lowering operation. A runaway snatch load, caused by slack in the winch cable, may result in damage to both the winch system and the equipment fitted to the pole. When lowering, the friction brake will engage within the winch.
7. Continue until the pole is lowered to its horizontal service position. Wind the winch handle clockwise so that the ratchet engages and two clicks are heard and allow pole to rest in the horizontal position.

Note, when winching 'out' a minimum of 3 wraps of cable **must** be left on the winch drum.

To raise pole

8. Turn winch handle clockwise to winch 'in' and raise the pole. A clicking sound will be heard from the winch ratchet engaging. When pole is fully raised to vertical position, keep tension on the winch cable so that it pulls the pole onto the base post and then fit the 2no retaining bolts and nuts.

Do not attempt to dis-connect the winch cable from the pole section until retaining bolts and nuts are secure.

9. Remove eye end of cable from cable anchor lug.
10. Pull the eye end of the winch cable through the pulley brackets in the post, winding the cable onto winch drum. Keep tension on the cable by hand ensuring that it is layered evenly and once cable is fully wound on to winch drum, secure in place so that the winch cable does not unravel.
11. Remove Winch unit.
12. Lock pole against unauthorised use by padlocking internally through the padlock bracket in the rear of the compartment.
13. Once the winch unit has been removed, keep the cable wound tightly and layered evenly on the winch drum. If the cable becomes loose/ unravelled, then it will be necessary to unwind the cable off the winch and re-layer evenly and tightly before operating the next pole.
14. The winch unit should be stored with care. Any alterations to the winch unit, separating it or modifying in any way will invalidate the warranty.

We recommend that a risk assessment is produced covering the operation of the pole. For a generic template, please contact our Sales office.

Winch - general operation notes

1. Never operate the winch by any other means than with the winch handle. **THE WINCH MUST NOT BE OPERATED WITH A POWER TOOL**
2. Ensure that ratchet engages on each operation (clicking noise will be heard when winding cable on to drum)
3. Never allow oil or grease to come into contact with the friction brake discs.
4. Ensure cable is wound tightly onto drum before operation.
5. Ensure winch is properly maintained - refer to guidance below.
6. Ensure operation as per Altron operating procedure
7. Ensure a minimum of 3 turns of cable on the winch drum before winch takes load.
8. IF IN DOUBT ASK (Call Altron technical on +44 (0) 1269 831431 or e-mail cctvsales@altron.co.uk)

Winch inspection and maintenance

Carry out the following checks and maintenance at least annually.

1. **WARNING!** Do not lubricate friction (braking) discs. This can cause slipping or failure.
2. Apply a drop or two of #30 weight engine oil to each bushing I.D. and to the ratchet pawl pivot points. Maintain a thin layer of chassis grease on the gear teeth.

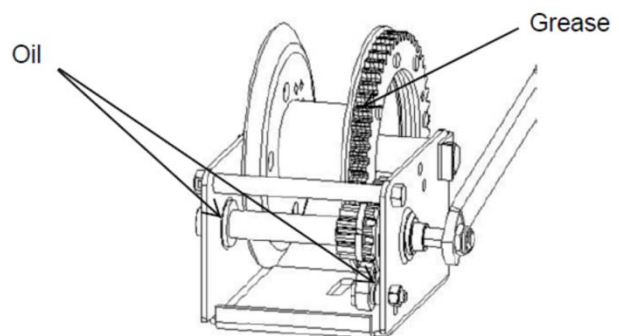
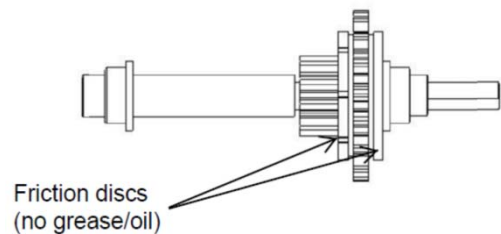

3. Check for wear on the gear teeth on the winch drum or gear on the primary shaft. If excessive replace winch. Check load being applied to winch as overloading will cause excessive wear.
4. Clean debris off winch and ensure grit and debris is cleared from gears
5. Check for any damage that has taken place i.e. denting or distortion on the winch drum or winch casing – if present then replace winch.
6. Inspect the winch cable for fraying, kinks or flattening along its full length. If the winch cable is frayed, flattened or kinked; replace. Investigate why fraying or flattening has occurred.
7. Check the friction (braking) discs for wear. If less than 1.5 mm thick, cracked or broken, replace immediately.
8. During winch use, check for proper ratchet pawl operation as follows. When cranking cable in, a ratchet clicking sound should be heard. When cranking cable out, there is no clicking and the ratchet pawl must be fully engaged into the gear teeth. If this does not take place, then stop using the winch and contact Altron.